



Roman Gassmann

Graduate Candidate	Roman Gassmann
Examiner	Prof. Dr. Heinz Mathis
Co-Examiner	Stefan Hänggi, RUAG Electronics, Bern
Master Research Unit	Sensor, Actuator and Communication Systems (SAC)
Project Partner	National Instruments Switzerland Corp., Ennetbaden AG

## Channel Simulator using NI Equipment

### 14 An Approach Using a Proprietary FPGA Platform

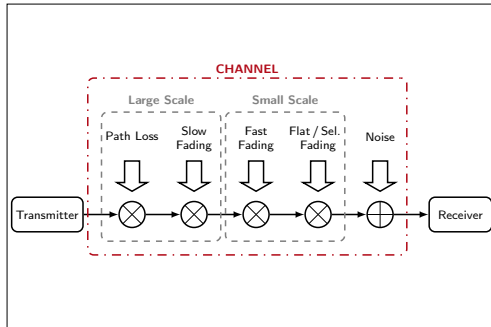

Block diagram of a radio communication channel and its different types of effects

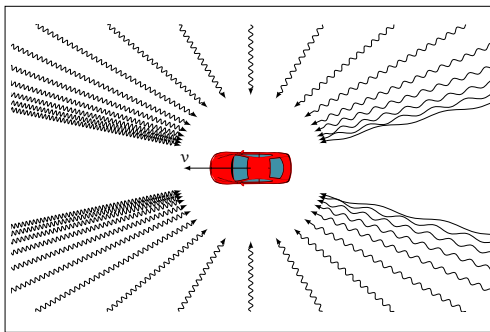

Clarke's model: the received signal exhibits a Doppler spread, due to the motion of the receiver

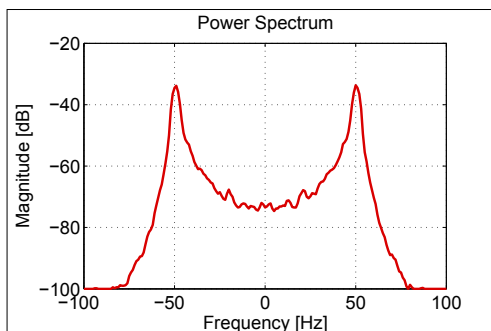

Measured spectrum of the implemented Doppler spread model

**Problem:** Testing radio communication systems in the field is both time-consuming and expensive. To obtain representative results, numerous trials need to be carried out, where the environment must obviously be the same as in the final application. Further, in the development phase, it is advantageous to be able to test the system improvements in a short time. Thus, it is useful to have a device which is able to simulate the channel. Such a device can be used to test RF systems and their behaviors in difficult channels, without having to search for the right environment in practice. Additionally, simulations in laboratories allow tight control of different effects, so that rare channel conditions can also be tested with a minimum of effort.

Generally, even simple channel simulators, with several restrictions in the configuration of effects, are very expensive. Prices of several hundred thousand dollars and more are common. The purchase of such a device therefore needs to be carefully considered.

**Task:** The ICOM laboratory of the HSR is equipped with a highly flexible measurement and automation device made by National Instruments. The first part of the assignment is to look into the possibilities of implementing a channel simulator on this device. In the second part a specific model of an essential effect is implemented in an adjustable form, suited for applications in various channel configurations.

**Solution:** Research on numerous well-known effects in radio communication channels showed that large-scale fading effects are mostly due to signal attenuation and are generally simulated by multiplying the signal with specific model parameters. On the other hand, small-scale fading effects, generally simulated by computationally demanding empirical models, seem to be a more appropriate and also challenging task for the available hardware. In this context, the consequences due to the Doppler effect are a well-known problem, combining the most essential issues in mobile communications: a dynamic setup of receiver and transmitter in a multipath environment. Thus, the focus of the second part of this project is on the generation and implementation of the classical Doppler spread.