



Andreas Ziegler

Graduate Candidate	Andreas Ziegler
Examiner	Prof. Reto Bonderer
Co-Examiner	Urs Reidt, Hamilton Medical AG, Bonaduz GR
Subject Area	Embedded Software Engineering
Project Partner	Sportec AG, Hri ZH

Mobile Data Logger

Mobile data logger for recording decentrally captured dynamic motor vehicle data

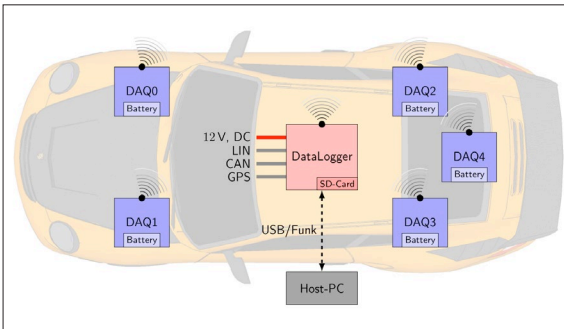

The position of the DAQ modules and the mobile data logger

Problem: The company Sportec AG from Hri ZH is a professional tuner for cars and is also active in motor sports. To analyse and optimise the driving dynamics of racing cars, Sportec AG needs a measurement system. With this system it should be possible to measure highly dynamic processes, like length changes of the dampers. At the same time, slow processes like the oil temperature should also be captured over a longer time, and the position of the car should be logged by the system with a GPS receiver. Because of the rough environment, the A/D converters should be placed close to their sensors. To reach this goal, the system will be realised as a distributed system with data acquisition (DAQ) modules, which already exist, and with a central data logger.

Proceeding: In the analysis, the specification for the mobile data logger has to be undertaken as the first step, according to the job description. In the next step, the best fitting hardware has to be evaluated and ordered. After the hardware is chosen, the development of the software, starting with the analysis and followed by the design and the implementation, must be carried out. At the end the whole mobile data logger (hardware and software) has to be tested.

Result: The PandaBoard running Ubuntu Core was chosen as the embedded platform. Ubuntu Core has a very small footprint but still allows for the installation of a lot of standard Linux packets. The mobile data logger software allows five DAQ modules to connect over a WLAN. Over these connections, the DAQ modules are configured and the measurement started and stopped. With IEEE802.15.4 broadcast messages every 250 ms over an XBee module, the five DAQ modules are kept in sync. The sensor data which the DAQ modules send over WLAN are received by the mobile data logger software and saved to a file on an SD card.

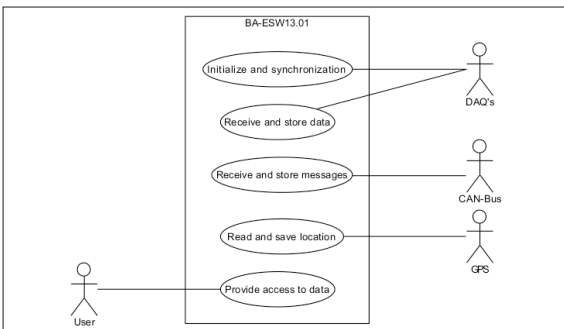

The use case diagram of the mobile data logger software

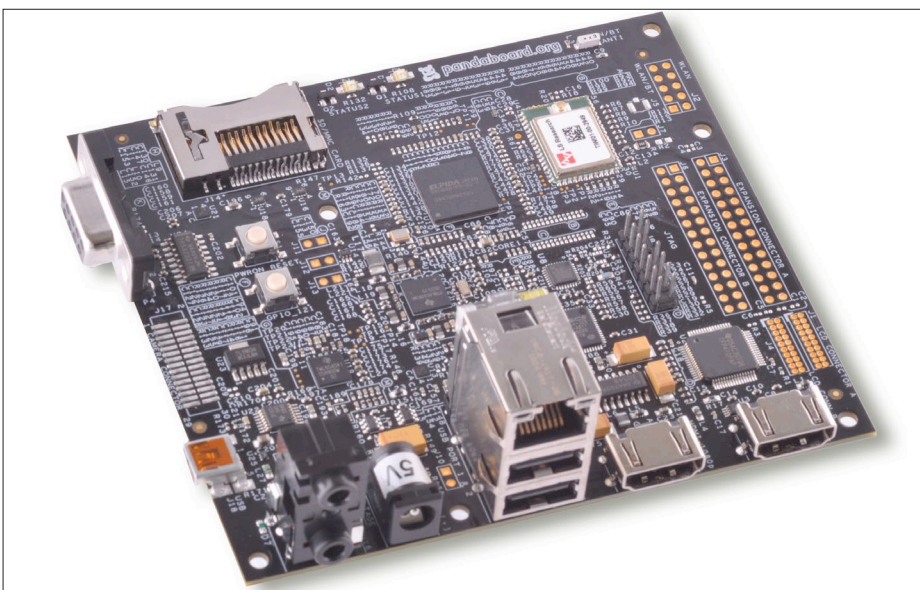

The PandaBoard