

Amodal 3D Object Detection with Microsoft Hololens2 for Industrial Object Domain

Student



Patrick William Zellweger

Introduction: In the project ZMC-VR-AI-Agent, the company Zellweger Management Consultants AG pursue developing a core module to classify and localize objects (3D object detection for indoor scenes) in an industrial domain and deliver interactive results to the user (e.g., object, locations, statistics). The core module is used within several analytic tools to optimize processes in the industrial environment. For that purpose, the RGB-D dataset “ZMC_Industrial_Dataset” is built up.

Approach / Technology: The augmented reality device Microsoft Hololens2 is used as the data acquisition platform. The Hololens2 has several built-in sensors (e.g., RGB camera, ToF depth camera, ..) to capture environmental information. The sensor streams of the device are accessible through the Research-Mode provided by Microsoft. Further, Hololens2 extends the user capabilities and experiences by bringing the digital data (e.g., object detection output) to the real world in a mixed-reality manner.

This research aims to check out the abilities of the Hololens2 for the above-described use case. In a first step, the data acquisition with Hololens2 is implemented to capture RGB-D data and process a 3D scene reconstruction. The captured data is used to build up the “ZMC_Inudtsrial_Dataset.” In a second step, research is done to evaluate a state-of-the-art approach for 3D object detection in indoor scenes with the underlying data/system. A concept for implementation is worked out. At least a first mockup of a DNN (Deep Neural Network) for a 3D object detection network is implemented.

Result: A workable data acquisition process is presented and imple-mented to build the Dataset. From a quantitative point of view, the reconstructed 3D scenes are satisfactory. Objects in the point cloud are detailed, and outliers/noise do not prevail. In the DNN part of this project, fundamental state-of-the-art research is done for amodal 3D object detection. Based on this research, an implementation concept is worked out and partially implemented. Due to the existing problems in train-ing performance the DNN development part is interrupted. The implementation must be im-proved/completed. The “Faster-AmodalNet” should be trained first on the NYUV2 dataset to compare performance with state-of-the-art and then transfer learned on the ZMC_Industrial_Dataset to make a final statement about the usability of Hololens2 for 3D amodal object detection.

Section View of reconstructed 3D Scenario
Own presentment

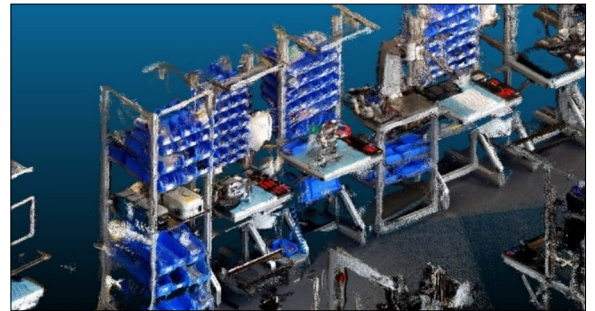

Faster-AmodalNet

Patrick Zellweger; Deng, Zhuo; Latecki, Longing Jan

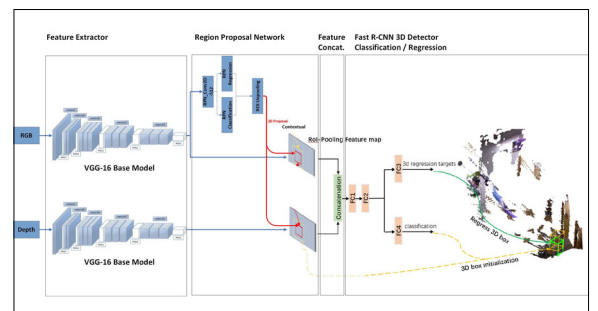

Examiner

Prof. Dr. Dejan Šeatović

Co-Advisor

Prof. Dr. Dejan Šeatović, Winterthur, ZH

Subject Area

Mechatronics and Automation

Project Partner

Zellweger Management Consultants AG, Pfäffikon, Schwyz