

Remote Radio Frontend for mioty LPWAN Base Stations

Graduate Candidates



Christoph Hälgi



Fabio Marti

Introduction: Swissphone Wireless AG provides alerting and communication solutions, including pagers and terminals as well as the corresponding broadcast networks. To add two-way communication capabilities independent from third party mobile networks, promising new LPWAN solutions based on the mioty standard are being developed by Swissphone to upgrade their existing networks. At the frequencies used, the cable loss caused by the physical distance between the base station and the typical roof-top antenna installations are no longer negligible. However, installing the base station hardware directly at the antenna is not feasible either.

Definition of Task: To decouple cable losses and allow for upgrading and usage of pre-existing installations, a remote radio frontend (RRFE) shall be developed for installation next to the antenna. On the base station side, an injector unit shall be developed, providing the interface for power, RF signals and control signalling between RRFE and base station.

The main challenge is posed by the requirement that all signals and the needed power shall be relayed to the RRFE using one single coaxial cable.

Approach: Various key functionalities and tasks were identified that needed consideration before a system prototype could be conceived, notably:

- Conceptual design of the necessary control signalling and its concrete implementation
- Design of a triplexer suitable for combining and separating all frequency ranges present
- Selection and testing of RF components such as amplifiers, filters, limiters, couplers, etc.

System overview (simplified block diagram)

Own presentation

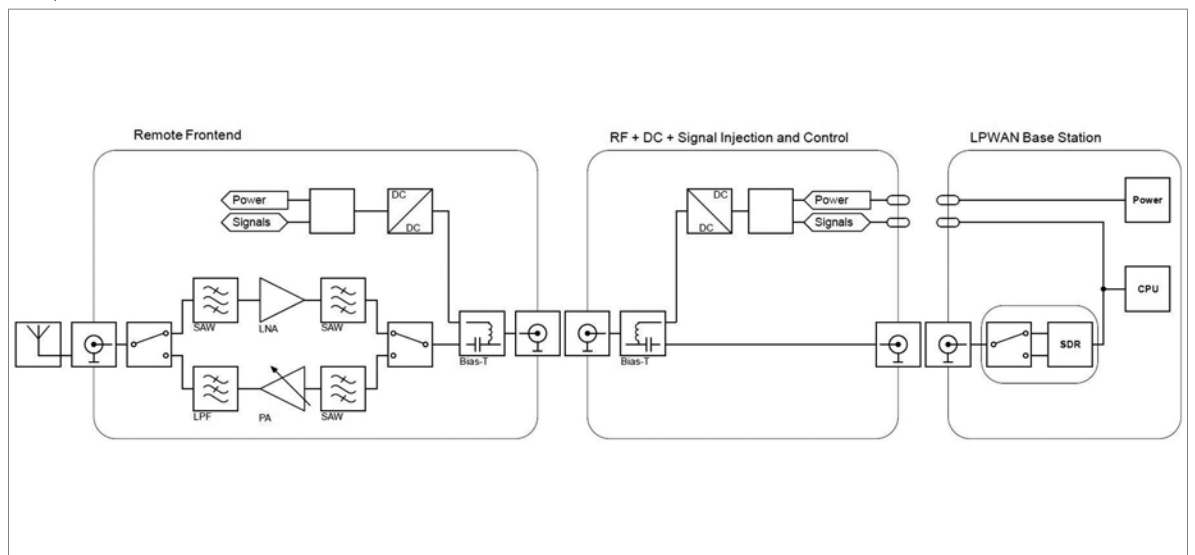

Based on the results of these considerations, a two-part hardware consisting of an injector unit and a remote frontend unit was conceived and realized according to key requirements. Testing of the hardware provided clues for further investigations of interest and for future improvements. The results exhibit good indications about the feasibility of the principal concept.

3D models of remote radio frontend (left) and injector (right) Hardware Units

Own presentation

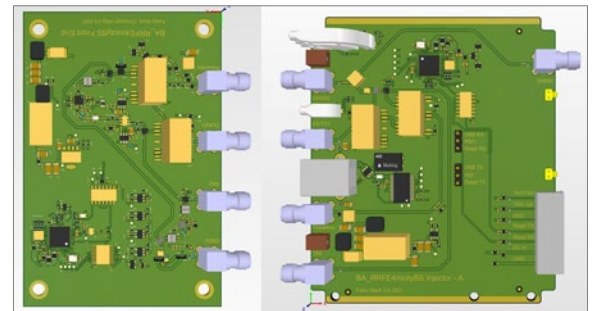

Triplexer simulation showing transmission parameters (dB) over frequency (MHz)

Own presentation

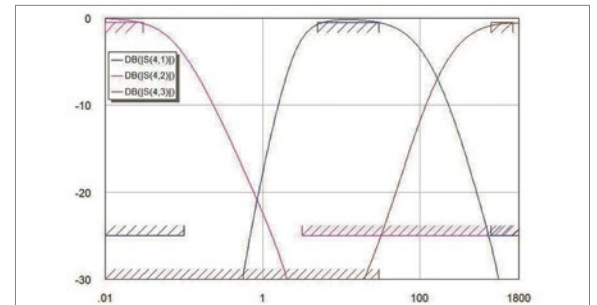

Examiners
Prof. Dr. Heinz Mathis,
Selina Rea Malacarne

Co-Advisor
Mischa Sabathy,
SPEAG, Zürich

Subject Area
Wireless
Communications

Project Partner
Swissphone Wireless
AG, Samstagern, ZH