

UWB for Data Transfer & Positioning

An Extension for LEGIC's Evaluation Board EVB-6310

Graduate Candidates



Flurin Arquint



Jan Brupbacher

Introduction: Wireless communication systems are central to today's world and are increasingly used in new electronic devices. For short ranges, the uprising Ultra Wideband (UWB) technology is used more frequently in the last years. UWB not only provides wireless data communication between different devices but can also be used to measure the distance separating them. This is achieved by measuring the signal propagation time, also called Time of Flight (ToF). This approach yields a safer and more precise measurement than other technologies, where the received signal strength is utilized. Due to the fact that UWB offers these measurement properties, it is found in positioning applications as well, such as in the recently introduced Apple AirTag.

Definition of Task: LEGIC Identsystems AG is interested in utilizing the UWB radio technology in their systems and applications. With their LEGIC Security Platform they provide end-to-end security for smartphone- and smartcard-based access, mobility, shared resource and industrial IoT applications. One of their security modules, the LEGIC SM-6310, supports all relevant smartcard technologies, Bluetooth Low Energy and NFC. With a designated hardware and firmware extension for its evaluation board EVB-6310, testing of the new UWB technology should be made possible for LEGIC customers. With the extension, communication, ranging and multilateration between devices should be made possible using UWB. A potential hardware arrangement is depicted in Figure 1.

Result: A complete hardware and firmware extension for LEGIC's evaluation board EVB-6310 was developed. The hardware is displayed in Figure 2. The extension supports the newest IEEE 802.15.4z standard for UWB and enables the use of various UWB functionalities with LEGIC's evaluation board. With the implemented showcase scenarios, the effectiveness of UWB's data communication, ranging and localization abilities with LEGIC's hardware was shown. Distances could be measured with a standard deviation of 10 cm, which made the implementation of a positioning system possible. A recorded test run with the just mentioned system is visualized in Figure 3.

Examiners
Prof. Dr. Heinz Mathis,
Nicola Ramagnano

Co-Advisor
Mischa Sabathy,
SPEAG, Zürich

Subject Area
Wireless
Communications

Project Partner
LEGIC Identsystems
AG, Wetzikon, ZH

Figure 1: Block diagram of the developed UWB board and the existing evaluation board EVB-6310
Own presentation

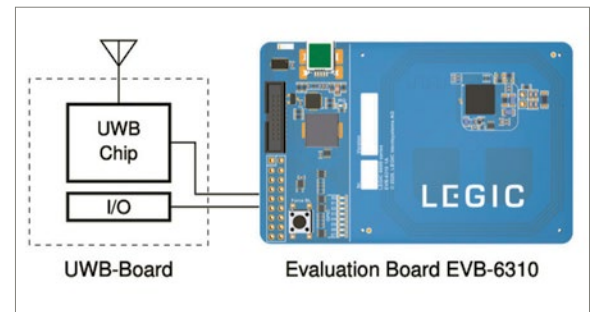

Figure 2: Developed UWB-Board
Own presentation

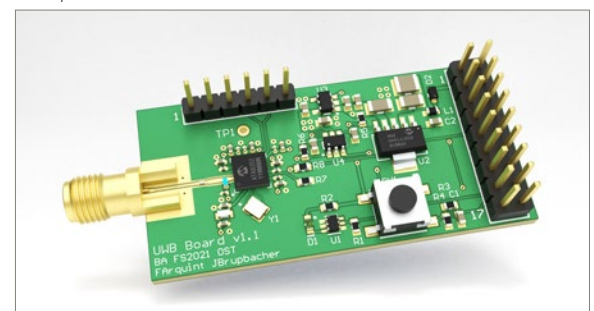

Figure 3: Measured tag positions whilst moving the tag in the office
Own presentation

